

JEWEL

Joint nEtWork for
European net-zero
manufacturing Leadership

Euroclusters 2025-2027



Co-funded by
the European Union



Co-funded by the European Union. Views and opinions expressed are however those of the author(s) only and do not necessarily reflect those of the European Union or European Innovation Council and SMEs Executive Agency (EISMEA). Neither the European Union nor the granting authority can be held responsible for them.

JEWEL

Pitches Sessions



Co-funded by
the European Union



Co-funded by the European Union. Views and opinions expressed are however those of the author(s) only and do not necessarily reflect those of the European Union or European Innovation Council and SMEs Executive Agency (EISMEA). Neither the European Union nor the granting authority can be held responsible for them.

MEMOCO

Systems integrator for TSO, serving **ELIA in Belgium and RTE in France**, as well as industrial clients connected to TSOs and Industrial Machines Manufacturers.

MeMoCo operates across three key areas:

- 1. ME**tering: metering solutions for billing purposes.
deployed in ELIA's 800 substations, on 100% of offshore platforms in France, and covering half of French territory for RTE. Numerous industrial sites are also equipped for sub-metering.
- 2. MO**nitoring: acquisition and transmission of critical data
such as transformer oil quality (DGA), power quality monitoring (PQM), industrial productions & consumptions, key data of onsite Machines.
- 3. CO**ntrol: assembly, wiring, and installation of protection and control panels in high-voltage substations as well as remote control of PLCs.

- 📍 BELGIUM/ Wallonia
- 📞 Jérôme KERVYN +32 496 26 86 06
- ✉ Jerome.kervyn@memoco.eu



Co-funded by
the European Union



JEWEL





Projects idea / use case challenge

- When you are an industrial Machine Manufacturer => How to shift from a product-based model to a functional economy approach?
- First step is to connect the machines and centralize the data to have valuable insights on their use.
- Memoco has a significant track record in this field within the grid industry and ready to integrate his existing building blocks to :



Partner search

Option 1: SME Machines Manufacturers :
> 250k€ machines
> 10 machines per year

Option 2: Energy-Intensive Industries
+ Connected to HV grid
+ Multiple tenants
+ Needing submetering & transformers monitoring

Outside Wallonia

BUTTON HOP

- Industrial IoT solution for real-time operational management
- France / Pays de la Loire
- Alexandre GRIERE – CEO
- +33 6 33 43 12 93
- alexandre.griere@button-hop.com

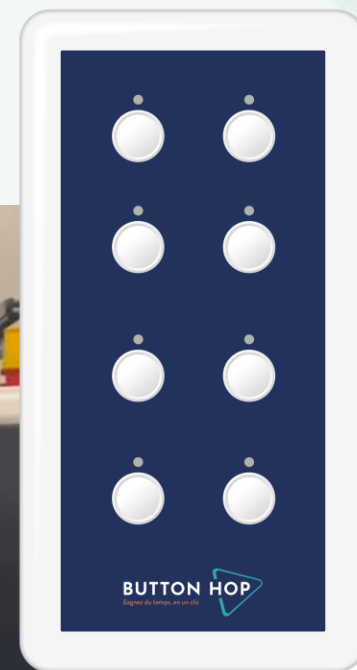
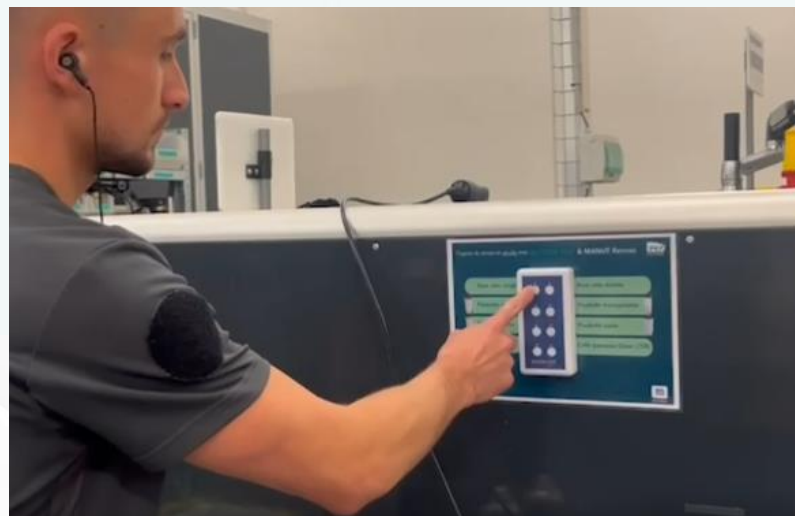

Co-funded by
the European Union



JEWEL

BUTTON HOP
Gagnez du temps, en un clic



Projects idea / use case challenge

- In many factories, internal support processes are inefficient.
 - Operators walk long distances to find support
 - Problems are reported late or in Excel
 - Machines continue running while waiting for help
- This creates **lost productivity and unnecessary energy consumption.**
- We want to develop a **Carbon Lean module** integrated into Button Hop.
- This module will measure:
 - unnecessary operator movements
 - delays before interventions
 - machine idle time
- The objective is to **quantify the carbon and energy impact of operational inefficiencies.**



Partner search

- We are looking for:
 - **Industrial partners** willing to test the solution
 - **Technology or research partners** with expertise in carbon footprint analysis
- Priority sectors:
 - energy-intensive industries
 - automotive
 - aerospace

INSULA France

- R&D, performance tests on thermal-related issues
- France / Pays de la Loire (Nantes)
 - Founded 2008, previously active in energy efficiency audits
 - performance tests on heat exchangers (nuclear)
 - Large experience in temperature & flow measurements, has own lab.
 - Partner in several national R&D collaborative projects
 - European patent release summer 2026, based on real-world tests
- Contact person: Luc Traonvouez, contact@insula-france.com





Projects idea / use case challenge

- Compact, waterless, high power thermal heat storage with specific latent material and "pillow plate" heat exchangers
- This Thermal battery addresses
 - industrial batch processes with heating+cooling
 - improved integration of renewables
 - peak demand shaving
 - Power to Heat
 - space heating & defrost of electric vehicles
- Expected license of patent & knowledge to industrials willing to manufacture and sell such thermal batteries



Partner search

- Industrial or group of industrials, active in heat exchanger/"pillow plate" manufacturing



- License agreement according to applications, countries, duration

RENARDO

- Industry – Predictive maintenance
- France / Nantes
- Jessie Coiffard
- jessie.coiffard@renardo-tech.fr

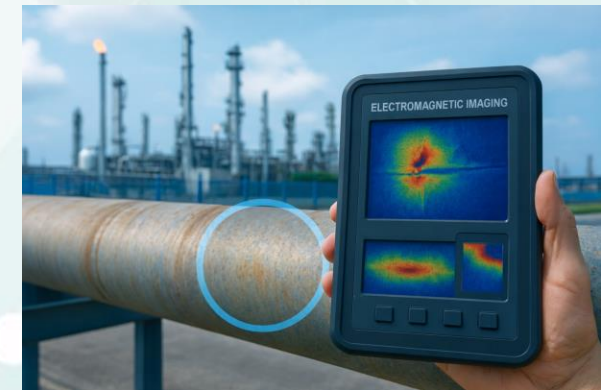



Projects idea / use case challenge

- Intelligent monitoring of industrial power networks and energy efficiency through an electric field imaging sensor integrated into a drone
- Grid techno
- Early detection of electrical anomaly or faults, optimization of energy efficiency and reduction of carbon emissions in industrial power networks



Partner search

Looking for :

- Company that develops high-voltage line inspection drones to integrate a novel sensor
- Electricity network operator for on-site testing

- We turn old smartphones into tiny computers at scale for the industry

1.



2.



3.



4.



- Belgium/Wallonia
- J-B Feron - jbf@citronics.eu



Projects idea / use case challenge

- We provide **circular, performant, open** computing & connectivity capabilities for **IoT** and **edge computing** applications
- Net zero tech
 - Circular economy
 - Local supply
- Impacts
 - ~50% CO2 eq. reduction
 - Improved perf. to cost ratio
 - Reduced supply risk
 - Shorter time-to-market



Partner search

- Partner profile
 - Manufacturer
 - integration partner
 - smart product solution owner
 - Industrial end-user
 - Target sectors:
 - industry
 - energy
 - telecom
 - ...

European Quality Assurance Spain S.L. – EQA

- ✦ EQA is an international certification, verification and inspection entity, with more than 30 years of experience, specialized in ESG standard. Most of our services are accredited by ENAC (National Accreditation Entity).
- ✦ Spain / France / Europe
- ✦ Alexandre Morcillo Lenoble
Climate Change and Circular Economy International Business Developer
alexandre.morcillo@eqa.es
Mobile: +34 607 60 85 21 / www.eqa.org / www.eqacertification.fr



JEWEL





Projects idea / use case challenge

- EQA is seeking a partnership to provide independent verification of climate-change mitigation and emission-neutrality commitments, including DNSH (Do No Significant Harm) validation, Life Cycle Assessment, EU-ETS etc., to ensure that the project meets EU sustainability and compliance requirements.



Partner search

- EQA is looking for a technology or industrial partner involved in Net-Zero solutions (renewables, hydrogen, batteries, smart-grid, energy-efficiency, or circular-industry technologies).
- The partner should provide technical data, performance evidence, or emissions metrics that EQA can independently verify. We welcome partners from any EU country, ideally those deploying or developing low-carbon technologies and needing third-party climate-neutrality and sustainability validation.

MAVARICK

- **Bridging tech-savvy AI with end-user manufacturers**
Mavarick deploys supply chain intelligence that maps supplier dependencies, quantifies true cost exposure, and eliminates procurement blind spots.
- Ireland / Limerick
- Dr. Paul Byrnes, CEO & Co-founder, Mavarick
Email: paul@mavarick.ai



Projects idea / use case challenge

Industrial Challenge

Automotive manufacturers cannot see **resilience risks, true cost exposure**, or decarbonisation levers across their Tier 1 and Tier 2 supplier base. Procurement decisions are made on incomplete, unverified data.

NZT related

Transformative digital industrial technologies enabling supplier dependency mapping, embedded carbon quantification, and **net-zero-aligned procurement decisions**.

Expected results/impacts

Verified supplier intelligence deployed across an automotive manufacturer's supply chain, **enabling measurable reduction in resilience risk, cost exposure**, and emissions baseline reporting burden.



Partner search

- Seeking a **European automotive manufacturer** (Tier 1 supplier or OEM-adjacent) with complex, multi-tier supply chains looking to pilot AI-driven supplier intelligence for resilience and net-zero compliance.



Co-funded by
the European Union



JEWEL



SOLERON ENERGY

- **What we do:** Optimizing renewable energy production and consumption and participating in the frequency reserve market
- **Where we operate:** Estonia, Baltics, EU
- **Get in touch:** Teet Kukk, CEO, teet.kukk@soleron.ee





Projects idea / use case challenge

- **The problem:** Asset owners lack smart control and automated trading to maximize returns
- **How we solve it:** Full stack solution with our own controllers, trading platform and direct SCADA control for wind and solar
- **The tech behind it:** Integrating wind, solar and battery storage into daily frequency markets
- **The results:** Total asset flexibility and maximized profitability



Partner search

Let's team up

Who you are: Renewable asset owners, developers and local BSP/BRPs

What **you bring:** Readiness to enable direct SCADA control and integrate assets with our trading platform

Your industry: Renewable energy generation and grid balancing

Where you operate: Baltic States, EU

- Production Planning and Scheduling in highly Complex Manufacturing Environments
- Germany / Bavaria
- Dominik Eibl, Co-CEO – d.eibl@deepsynergy.ai - +49 172 1829712



Projects idea / use case challenge

- AI-automated production planning for **high-complexity factories**, optimizing **capacity + energy/CO₂ constraints** to enable **Net Zero manufacturing**—fully integrated with **ERP/MES**
- Energy Efficiency
- 10-30 % Efficiency Increase incl. EnergyUsage



Partner search

- European **high-complexity manufacturers** (discrete/process), with **multi-stage production** and a clear need to improve **planning/production efficiency + energy/CO₂ performance**. Ideal partners have **ERP/MES in place**, operational planning pain, and willingness to run a **pilot** in a plant environment.

E F F E C T

MAKE IDEAL USE OF EXISTING RESOURCES WITH MINIMAL PLANNING EFFORT

RESULTS FROM CUSTOMER PROJECTS IN COMPLEX MANUFACTURING ENVIRONMENTS



10-30 %
EFFICIENCY
INCREASE

OPTIMIZED SEQUENCING,
ALLOCATION &
RESOURCE UTILIZATION



-70-90 %
PLANNING
EFFORT

ON DEMAND
REPLANNING WHEN
CHANGES OCCUR



<12 MONATE
ROI

FAST
MEASURABLE
RESULTS



amun OSRAM

CLIENT EXAMPLE: METALWORKING | HIGH COMPLEXITY



„Previously, it was impossible to consider all dependencies between production, setups, and staffing in planning - DeepSynergy.AI Production Planning delivers this in minutes today.“

Simon Schwarzfischer - Projectmanager, ams-OSR AM

SELECTED CUSTOMER PORTFOLIO

amun OSRAM

METAL PROCESSING



FOOD MANUFACTURING

KATEK

A Company of Kontron

ELECTRONICS | EMS



METAL PROCESSING

schatdecor

DECORATIVE &
SURFACE FINISHING

HEIDENHAIN

ELECTRONICS | EMS



ZERTIFIZIERTER SAP PARTNER



PROBLEM

MANUAL PLANNING CREATES **INEFFICIENT PLANS** - RESOURCES ARE NOT UTILIZED OPTIMALLY

CONSEQUENCES: IDLE CAPACITY AND DOWNTIME, HIGH EFFORT AND INCREASED RISK OF ERRORS, AND REACTIVE PLANNING INSTEAD OF KPI-DRIVEN DECISION-MAKING

PLANNING FACTORS



RESOURCES

MACHINES, MATERIALS, WORKFORCE



PROCESSES &

TECHNOLOGICAL DEPENDENCIES



EMPLOYEE AVAILABILITY

& QUALIFICATIONS



REGULATORY &
ESG REQUIREMENTS



SEQUENCE-DEPENDENT
SETUP & CLEANING TIMES



OPTIMIZATION &
PLANNING OBJECTIVES



INDIVIDUAL
INFLUENCES & DEPENDENCIES



COMPLEXITY:

ALL FACTORS MUST BE CONSIDERED SIMULTANEOUSLY

PLANNING TODAY
WITHOUT
DEEPSYNERGY.AI



**UNUSED
RESOURCES**

WORKFORCE, MACHINES, MATERIALS



**HIGH EFFORT
& ERROR-PRONE**

FIREFIGHTING INSTEAD OF STEERING



**REACTIVE & PERSON-DEPENDENT
PLANNING**

NOT KPI-DRIVEN

A CENTRALIZED SOLUTION FOR ALL PLANNING REQUIREMENTS

DEEPSYNERGY.AI PLANNING SUITE - A SET OF MODULES THAT, TOGETHER, FULLY COVERS THE PRODUCTION PLANNING PROCESS

DeepSynergy.AI PRODUCTION PLANNING SUITE



SEQUENCE-/

MACHINE SCHEDULING

SETUP MATRIX | SEQUENCE DEPENDENCIES
| BOTTLENECK MACHINES



INVENTORY &

MATERIAL PLANNING

SAFETY STOCK |
LEAD TIMES | MRP



DELIVERY /

LOGISTICS PLANNING

ROUTE PLANNING | TIME WINDOWS
| LOAD UTILIZATION



WORKFORCE PLANNING

SHIFT STAFFING | SKILLS MATRIX |
MULTI-MACHINE OPERATION



LOT-SIZE PLANNING

LOT SIZES | CAMPAIGNS | SETUP/LOT COSTS

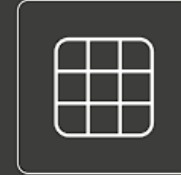

PARTS NESTING / PACKING

PACKING UNITS & PACKING INSTRUCTIONS
| LINE SEQUENCING

THE RESULT WITH THE PLANNING SUITE

IDEAL PLAN
IN MINUTES

| FULLY AUTOMATED DETAILED SCHEDULING & EXECUTION
| ON-DEMAND IN REAL TIME (CHANGES/DISRUPTIONS)
| PLANNING HORIZON FROM SECONDS TO MONTHS

OBJECTIVE-ORIENTED &
CUSTOMIZED

| MULTI-STAGE PROCESSES
| SHARED RESOURCES & BOTTLENECKS
| KPI-DRIVEN (UTILIZATION, DUE DATES, COSTS, ESG)

LET'S UNLOCK
THE FULL POTENTIAL OF
YOUR PRODUCTION PLANNING

WE LOOK FORWARD TO
YOUR CHALLENGES!



SCAN & BOOK A
MEETING (LINK)

„FULLY AUTOMATED. OPTIMIZED. MEASURABLE.“

DeepSynergy.AI

AI PLANNING
FOR REAL-WORLD
COMPLEXITY

DEEPSYNERGY.AI GmbH

EDUARD-RÜBER-STR. 7
83022 ROSENHEIM

KONTAKT@DEEPSYNERGY.AI
WWW.DEEPSYNERGY.DE

CESI POWER EXCHANGER

- Development of a new heat exchanger architecture designed to simplify HVAC systems and improve energy efficiency by up to 50% in residential buildings, based on a silicon carbide thermal core.
- Belgium/ Wallonia
- Alain PAULUS
 - paulusthermo2000@gmail.com
 - +32/470.17.87.23





Projects idea / use case challenge

- Decarbonizing buildings requires replacing fossil heating with heat pumps, but current HVAC systems remain complex and costly to deploy. CESI develops a silicon-carbide heat exchanger to simplify systems and improve efficiency (up to 50%).
- Energy efficiency and building decarbonization through advanced HVAC technology enabling lower electricity consumption and reduced lifecycle emissions.
- Up to 50% reduction in energy consumption, 80% lower lifecycle CO₂ emissions, and installation time reduced from ~15 days to ~2 days thanks to simplified HVAC architecture.



Partner search

- CESI is seeking financial investors, residential developers building large housing projects, and industrial partners to support pilot installations and market deployment. The technology benefits from strong foundations: manufacturing capability through Saint-Gobain Ceramics, preliminary technical validation by the Belgian research laboratory Cenaero confirming the first performance assumptions, and protection through a European patent.



ALKALINE TECHNOLOGIES SAS

- Waste management company
- France / Nantes and Italy / Turin
- quentin.wehrung@alkalinetech.com



Fabien MICHEL, 43
Cofounder, CEO
Nantes, France

Ecole Centrale Paris 2005
18 years in entrepreneurship
enertime (2008), Voltigital
(2019), Carborok (2022)



Quentin WERHUNG, 29
Cofounder, CTO
Torino, Italy

PhD in geochemistry
Expert in waste mineral carbonation



Projects idea / use case challenge

Innovation : Unlocking End-of-Waste for WtE bottom ash and EAF slags via metal recovery and mineral carbonation

Impacts

- Millions of tons diverted from landfill
- Millions of tons of metals recovered
- Permanent CO₂ storage
- Strengthening EU sovereignty
- Industrial decarbonization



Partner search

Target Sectors (business)

- WtE | Metallurgy | Cement
Critical raw materials | CO₂ & pollution control

Potential CEO late-founder

- Industrial scale-up experience
- Fundraising & EU ecosystem
- Cleantech / raw materials background
- Strong execution & sovereignty vision

ROMBio by GENKO

- AI-based Planning & Scheduling Software
- Belgium - Seneffe
- Marion Vanorlé - Product Manager

marion@genko.be

+32 476 37 40 10



Co-funded by
the European Union



JEWEL



Projects idea / use case challenge

- Join forces with a manufacturing SME to validate ROMBIO as a next-gen Energy & Carbon-Aware Production Planner, by
 - Modeling production activities: processes, machines, robots, and product changeovers
 - Integrating energy costs & carbon footprint into planning
- Goals: Optimizing resource usage to:
 - Reduce energy consumption & waste
 - Minimize machine idle time & product changeovers
 - Improve production efficiency & reliability



Partner search

Seeking manufacturing SMEs & applied research partners to pilot ROMBIO in real industrial environments, validate energy & CO₂ reductions, and co-develop scalable Net-Zero production planning models

INDUSTRIAL AM

- Large scale 3D-printing of metal components
- Norway / Nordland region
- Contact information
 - Thomas Borgen
 - tb@kph.no
 - +47 951 44 172



Foto: Industrial AM



Foto: Waam3D



Projects idea / use case challenge

- Challenge: Transforming industrial value chains by 3D-printing large metal components on-demand
 - **Size: 2 x 2 x 2m**
 - **Stainless steel, Titanium, Inconel ++**
- NZT: Minimizing world resource consumption through
 - **less spare parts**
 - **less machining waste**
 - **more re-use and repair**
- Result:
 - **Reduced down-time**
 - **reduced material use**



Partner search

- Our partners may be:
 - European partners
 - Part of existing industrial value chain (aerospace, defence or process industry)
 - Original Equipment Manufacturer (OEMs)
 - Equipment suppliers
 - End user
 - Tech. provider for 3D-printing
 - Front-runners in their field, aiming to reduce lead time and/or material use
 - **Willing to improve existing value chains**

Global Design Technology (GDTech)

- Engineering office
- Liège / Belgium
- Joseph.Marra@gdtech.eu / 0032 479 43 04 59





Technology provider

- ✦ The technology GDTECH can bring to a consortium is summarized in our brochure available using the QR code or the link of the previous slide.
- ✦ Some example of capabilities are illustrated in following slides.
- ✦ We stay available to evaluate your needs and see how we could answer.



Partner search

- ✦ Some industry having the wish to work on decarbonation
- ✦ Some industry willing to develop physic-based and/or data-based (using AI) digital twin

Global Design Technology (GDTech) - Examples

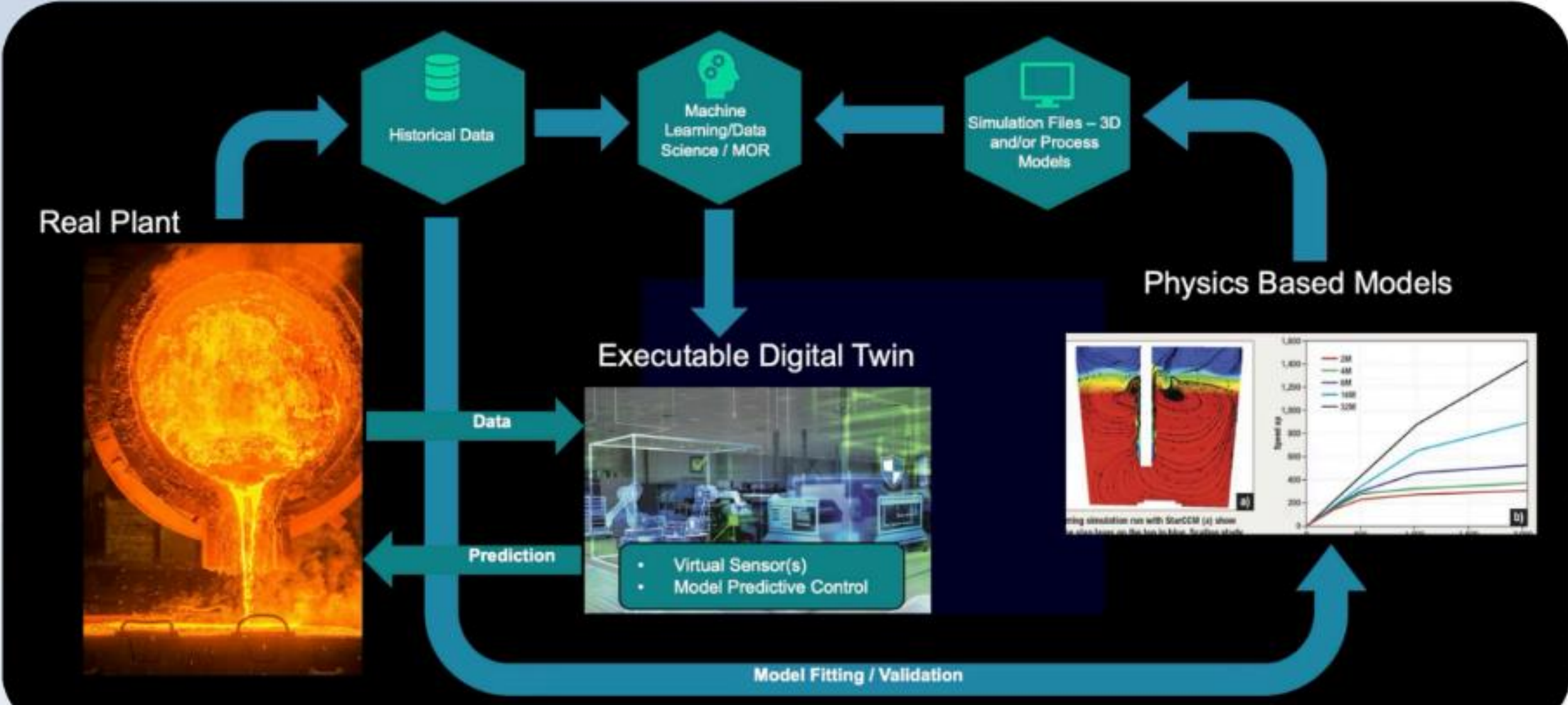

Global Design Technology (GDTech) - Examples

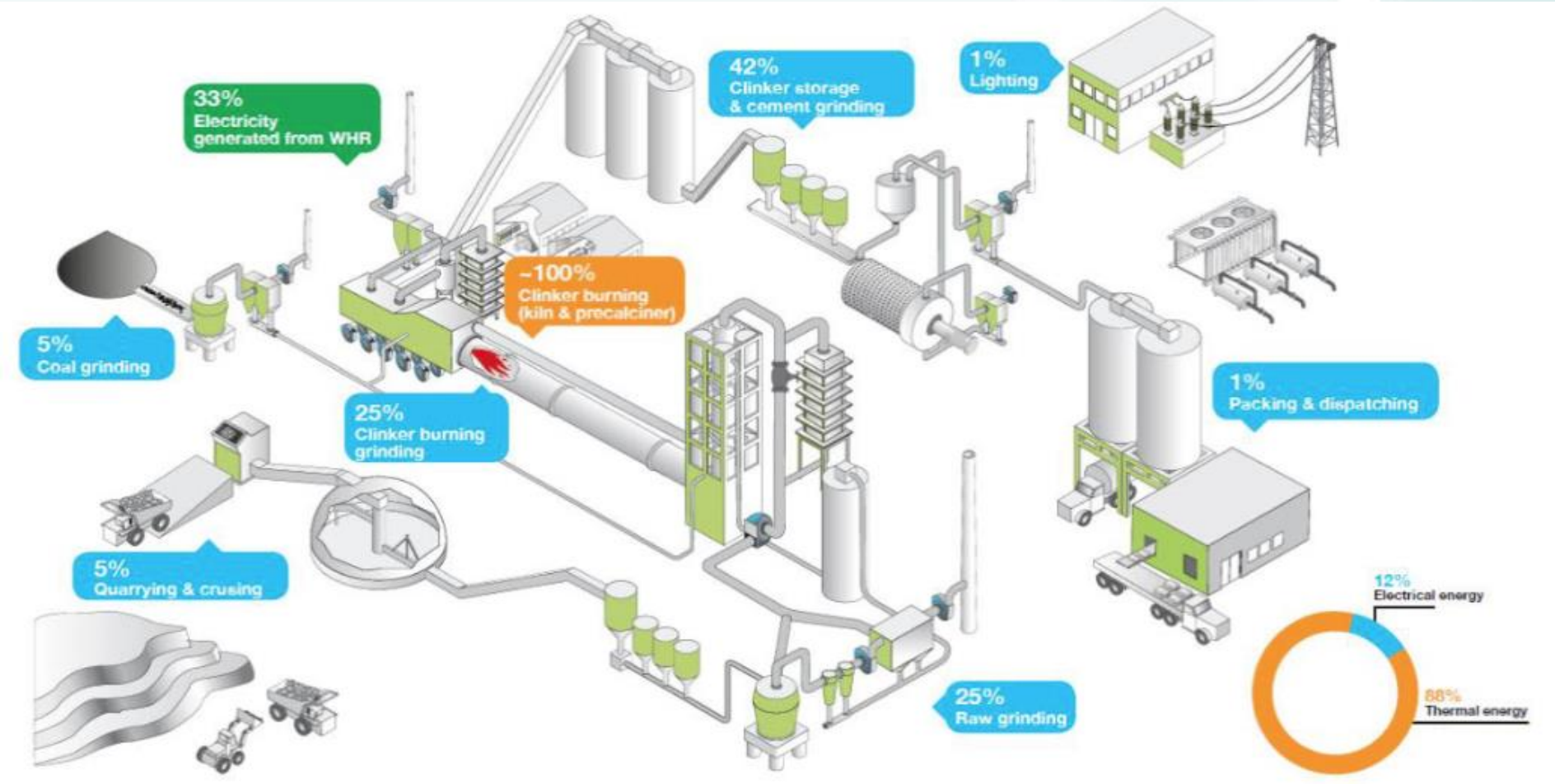

Global Design Technology (GDTech) - Examples

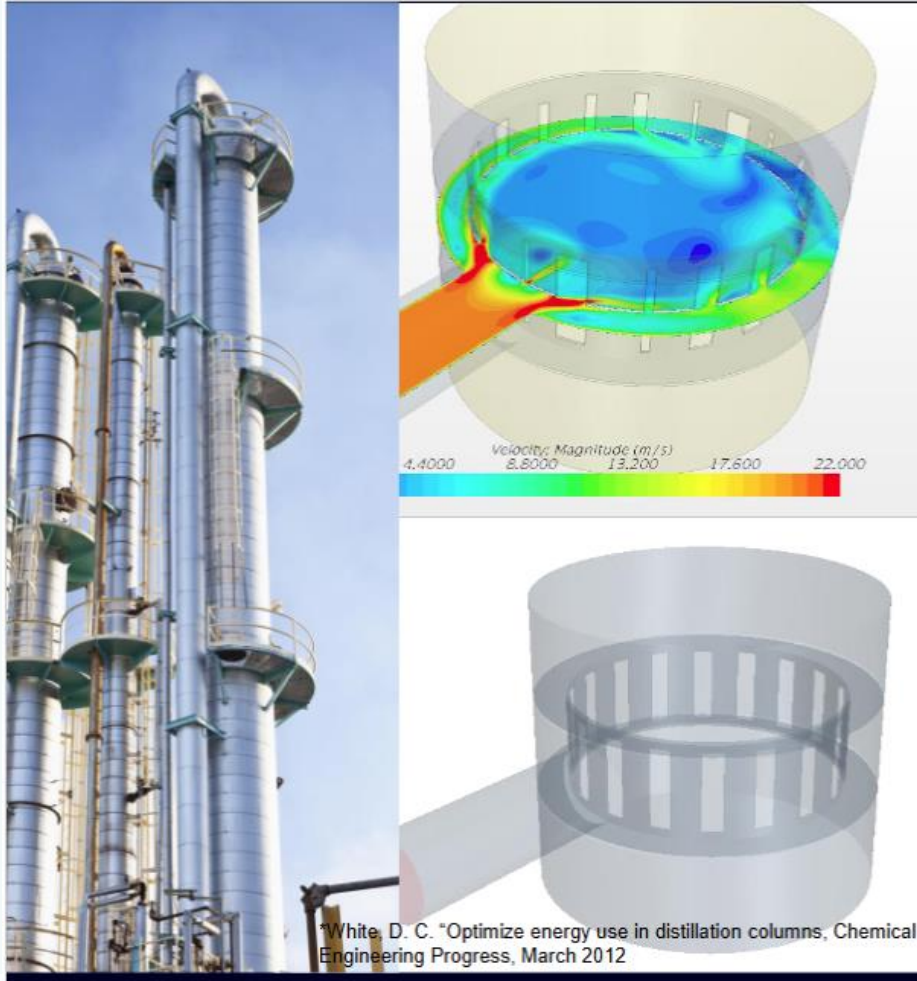

*White, D. C. "Optimize energy use in distillation columns, Chemical Engineering Progress, March 2012

Use Case: Better Design of Inlet device

Distillation Tower

- 40% of energy in refining is used by distillation units*.
- Siemens **Simcenter STAR-CCM+** is CAE (computer aided engineering) **software** that can analyze performance using fundamental physics
- Phenomenon such as flow, distribution heat transfer, in multiple phases can be analyzed
- Algorithms can be used to find **optimum operating conditions** or **design alternatives** that can balance complex parameters
- **Successful implementation** in chemical, food and pharmaceutical plants in Japan, USA, UK, S. Korea

10%
Increased
uniformity of
velocity up to
10% ↗

Reduced risk
of droplet
carryover ↘

Improved
separation
performance,
lower energy
costs



Co-funded by
the European Union



JEWEL



GDTECH
engineering

Global Design Technology (GDTech) – Examples



Use Case: Better Design & Efficient Operation

Fermentation

- Fermentation is complex process involving injection of gas (air) in to a liquid, suspension of solids, slow reactions
- Siemens **Simcenter STAR-CCM+** is CAE (computer aided engineering) **software** that can analyze performance using fundamental physics
- Phenomenon such as mixing quality, blend time, behavior of multiple phases can be analyzed
- Evaluate **oxygen distribution necessary for organisms** to survive based on stirring rate, air injection rate
- **Reduce shear that can kill organisms**

Optimize process to reduce power consumption, increase oxygen supply and protect micro-organisms from shear forces



Co-funded by
the European Union



JEWEL



GDTECH
engineering

Global Design Technology (GDTech) – Examples

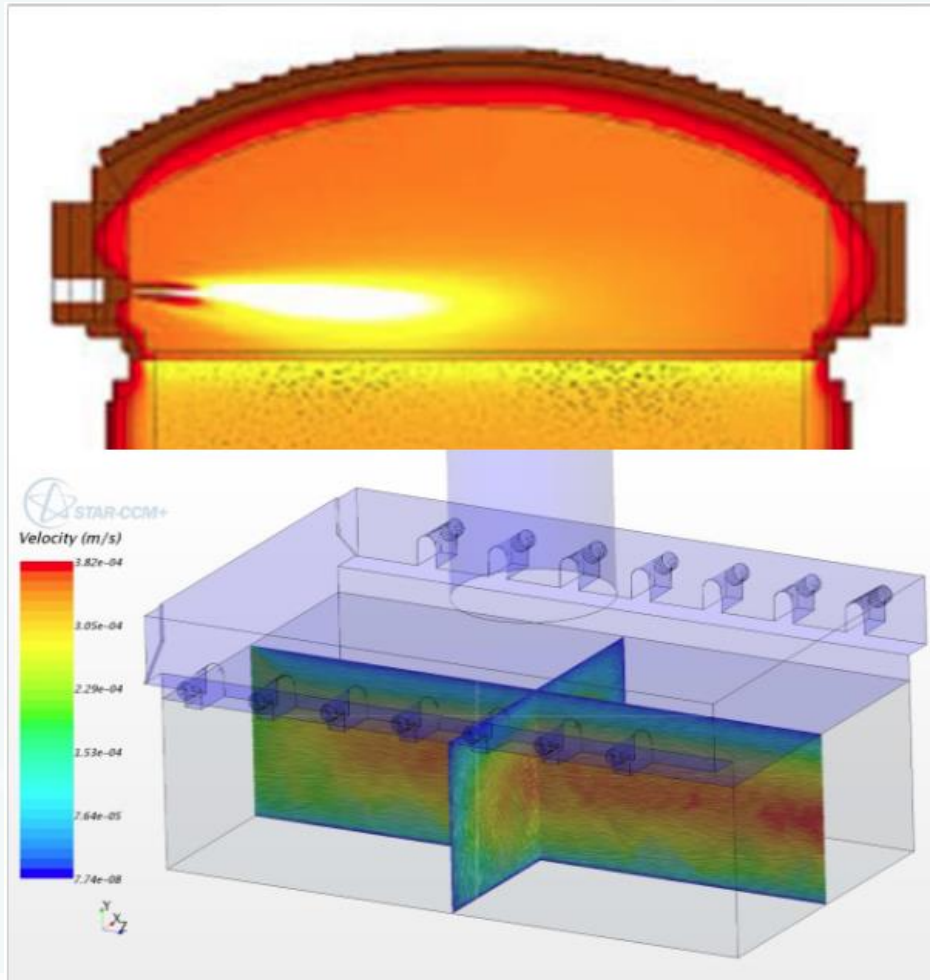

Use Case: Better Design & Operational Performance

Glass Furnace & Burners

- Glass industry is amongst highest energy consuming industry
- Modelling of physical and chemical processes including turbulence and combustion processes and their influence on glass melts can help improve the energy efficiency
- **Successful implementation** in glass industry in **Japan & USA**
- Siemens **Simcenter STAR-CCM+** is CAE (computer aided engineering) **software** that can analyze performance using fundamental physics

Understand
flame
behavior

Assess heat
transfer and
melt flow
behavior

Save energy
and meet
pollution
requirements



Co-funded by
the European Union



JEWEL



GDTECH
engineering

Global Design Technology (GDTech) - Examples

Shree Cements Improving Energy Efficiency using STAR-CCM+

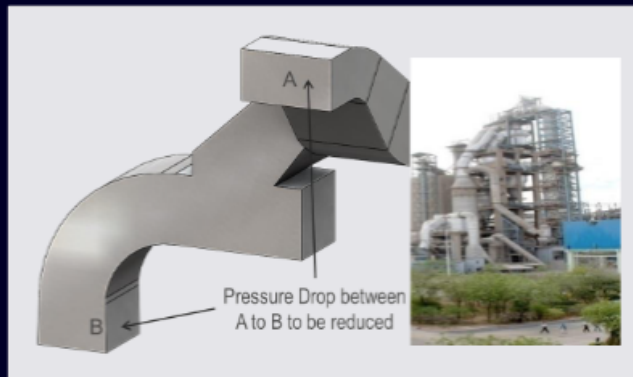

Extensive simulations to determine the optimal duct design for reduction in pressure drop

525%

reduction in pressure drop achieved resulting in high energy savings for fan power towards a company wide goal.



Solution applied to 3 units

Analysis of a V shaped duct to reduce pressure drop

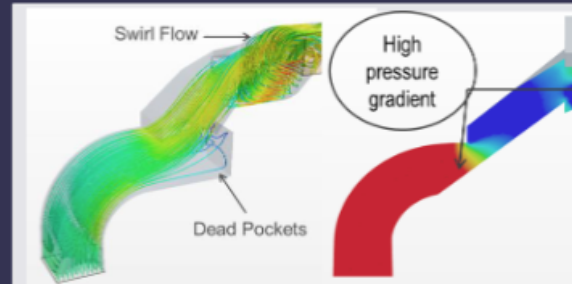

New design concept shows lower swirl and pressure loss

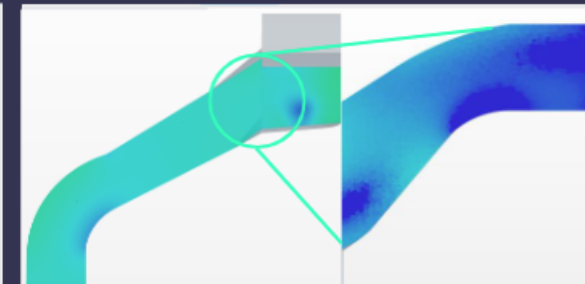

Analysis of a V shaped duct to reduce pressure drop

- Simulation indicated that particle accumulation leads to 135% rise in pressure drop



Ease of use STAR-CCM+ with integrated GUI starting from CAD to Results helped us to reduce the turn around time. Design variation study is quicker due to automated work flow"

Vipul Chandak, CFD Manager, Shree Cements, India



Co-funded by the European Union



JEWEL



GDTECH
engineering

Global Design Technology (GDTech) – Examples

ETEKINA EU project – Horizon 2020 research and innovation program Heat pipe technology for thermal energy recovery (WHRS) in the ceramic industry

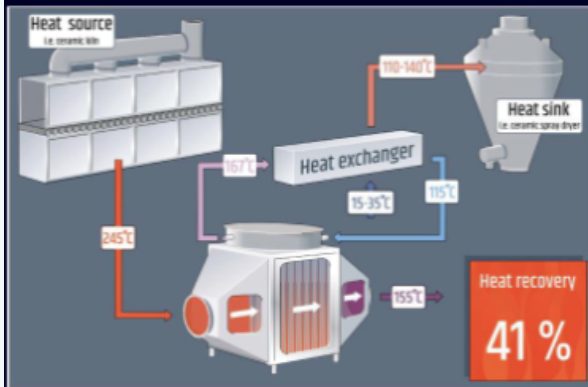

- Improve the energy efficiency of highly demanding methane and electricity consumers as the ceramic industry (1.5 billion m³ and 1800 GWh per year)
- Assess the reduction of gas emissions and energy costs adopting waste heat recovery systems

Ceramic tile manufacturing

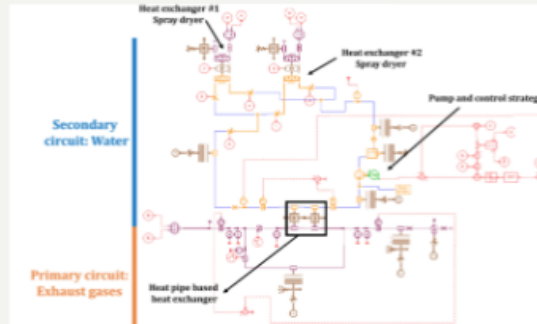

Simcenter Amesim simulation model, including the heat-pipe based heat exchanger

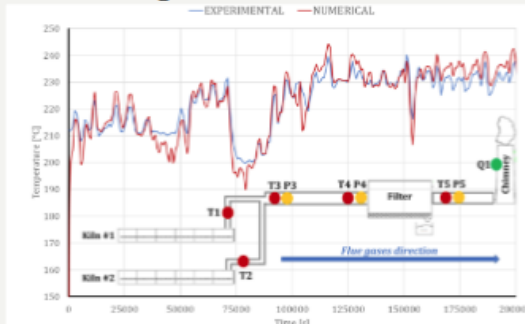

Model validation with temperature measurements for 2 days (no HPHE)

- Simcenter Amesim simulation model validated against experimental campaigns on the real facility with the traditional tile manufacturing process
- Evaluation of the thermal performance of the new heat recovery system consisting in a primary circuit (exhaust gases from the ceramic furnaces) and secondary circuit (water circuit)
- Development of proper control strategies to maintain the product quality through the spray drying process, independently from the exhaust temperature and flow fluctuations
- The heat recovery system reduces the spray dryer natural gas consumption by about 40%

International Journal of Thermofluids 10 (2021) 100080 – M. Venturelli & al.: Comprehensive numerical model for the analysis of potential heat recovery solutions in a ceramic industry

Global Design Technology (GDTech) - Examples

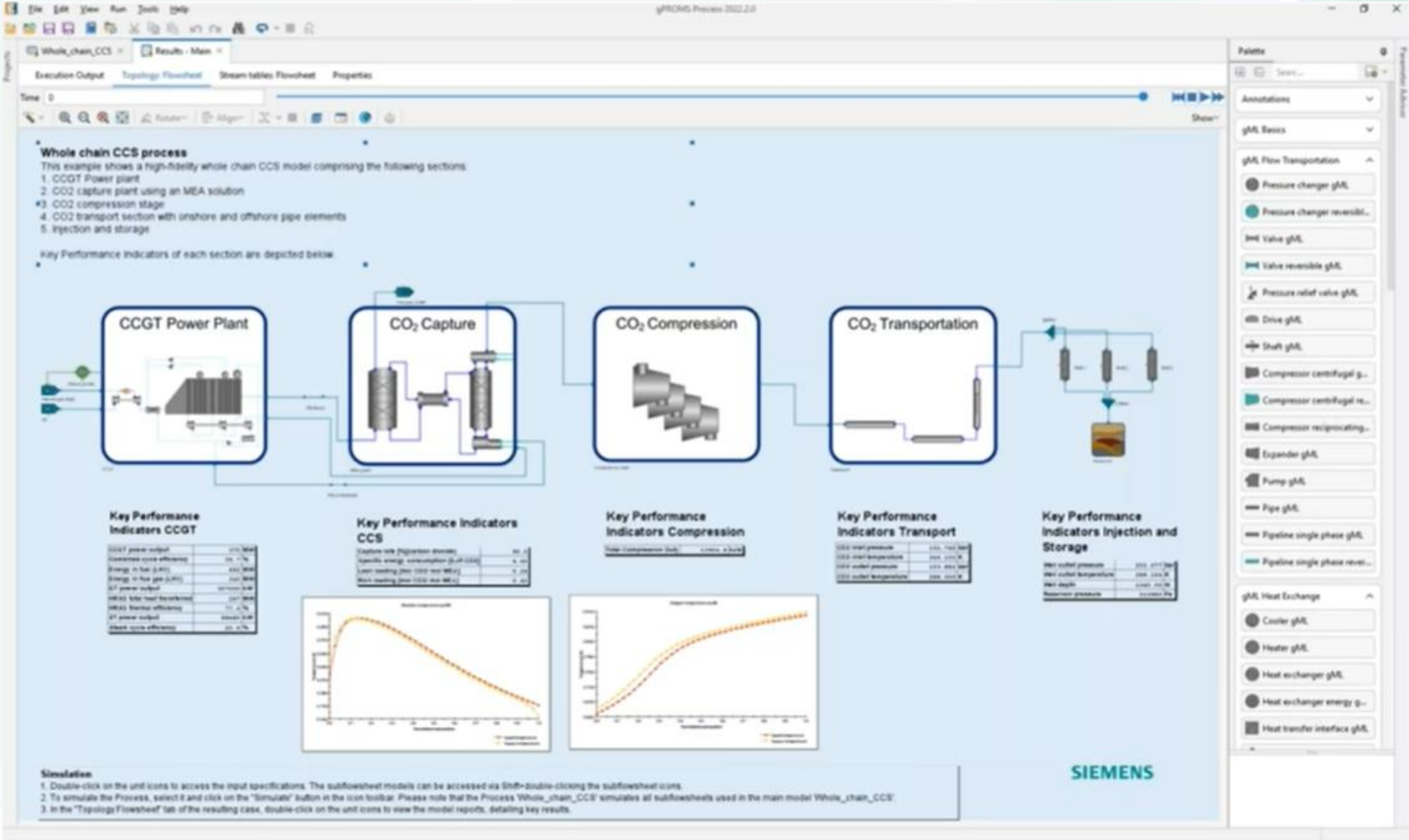

Global Design Technology (GDTech) - Examples

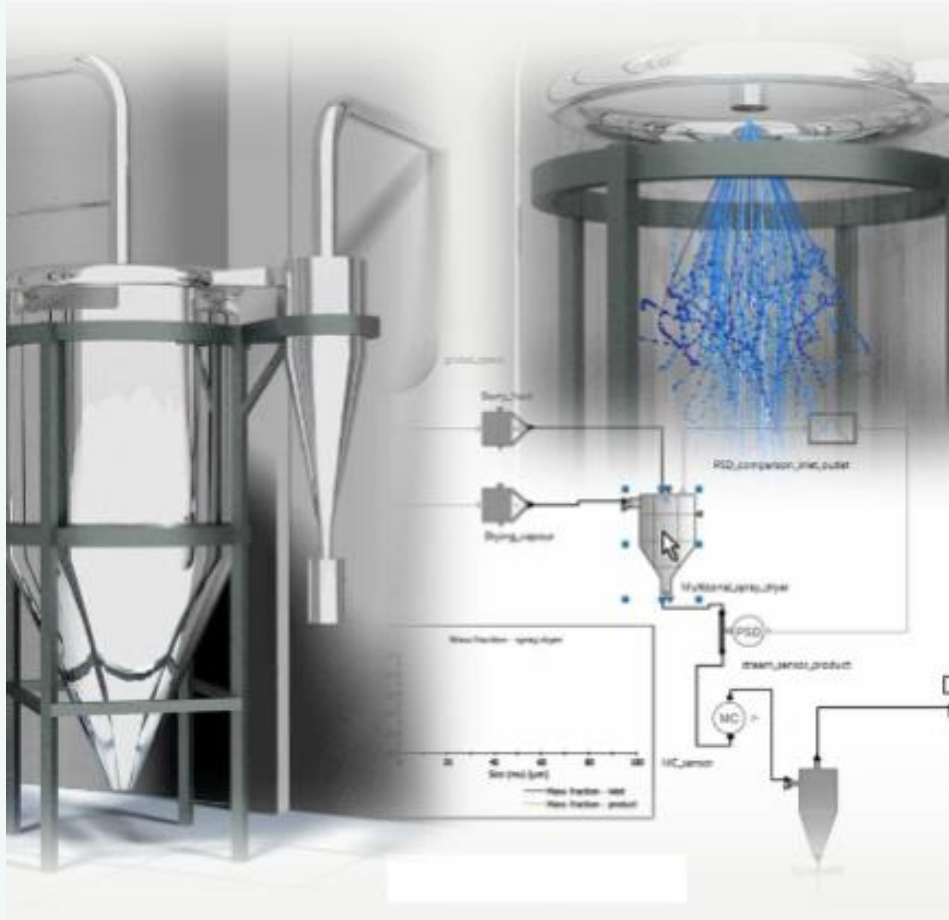

Combination of GPROMS and STARCCM

Global Design Technology (GDTech) - Examples

Climate change & the process industries Addressing the decarbonization challenge

CCS / CCU

- CO₂ Capture
- CO₂ Utilization
- CO₂ Storage



Hydrogen

- Production
- Transportation
- Storage
- Use



Sustainable feedstocks

- Recycling
- Circular economy
- Bio-based feeds



Efficiency improvements

- Energy efficiency
- Process intensification
- Demand-side management

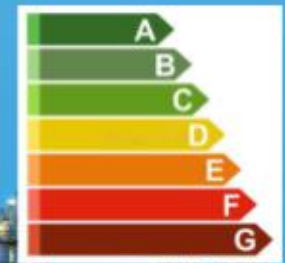

Co-funded by
the European Union



JEWEL



GDTECH
engineering

Global Design Technology (GDTech) – Examples



New hydrogen processes

Siemens' gPROMS technology is widely used to design electrolyzer processes for optimal handling of varying energy availability



Carbon capture, utilization & storage

Siemens is a pioneer in modeling tools for carbon capture, utilization and storage processes to ensure optimal design and operation



Fuel cell car development

We work with major automotive companies to accelerate development of next-generation hydrogen fuel cell cars



Greener process routes and catalysts

gPROMS digital process design tools for reaction engineering accelerate the development of green process technology, helping you to bring new reactor concepts and catalysts to market faster



Biofuels process development

Our biofuels digital twin technology helps companies to optimize processes and scale systems rapidly



Site-wide emissions reduction

Siemens' gPROMS emissions optimization technology can be applied to any large site to reduce emissions daily

Global Design Technology (GDTech) – Examples



Demand-side management

With the share of renewables increasing, grid operators are incentivising large users to adjust demand. Digital technologies help optimize every decision.



Pyrolysis of solid waste materials

Our gPROMS digital design technology can help get to grips with one of society's most pressing problems – dealing with solid waste



Carbon utilization

Siemens' considerable expertise in Fischer-Tropsch Gas-to-liquids (GTL) technology can help reduce time-to-market for carbon utilization processes

JEWEL

Closing Word



Co-funded by
the European Union



Co-funded by the European Union. Views and opinions expressed are however those of the author(s) only and do not necessarily reflect those of the European Union or European Innovation Council and SMEs Executive Agency (EISMEA). Neither the European Union nor the granting authority can be held responsible for them.

Next Steps : Let's have a Talk

Were you inspired by a pitch ? Get in touch with the speaker.

You have a question / A project idea you want to share / you need **Guidance** ? Get in Touch with the JEWEL Team :

- ✦ Connect with us via the [Helpdesk](#).
- ✦ If you are member of one of the partners*, you can also contact your usual cluster representative

**MecaTech, MECH, CIMES, EMC2, PoolNet, Evoluma, GreenTech, Merinova*



Co-funded by
the European Union

